

# #7671 REPLACEMENT TRANSMISSION FOR THE RC10GT

## step 1

### SET UP DIFF GEAR

- 1 Add a generous amount of #6591 diff lube to the #7664 differential gear holes and push the twelve large #6581 diff balls into the holes. Then push back in the lube that came out.
- 2 Insert one #6589 bearing into the gear.

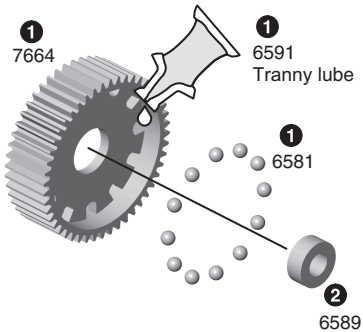

## step 2

### SET UP LEFT HUB

- 1 Push the #6582 spring and #6575 T-nut into the #7668 left outdrive.

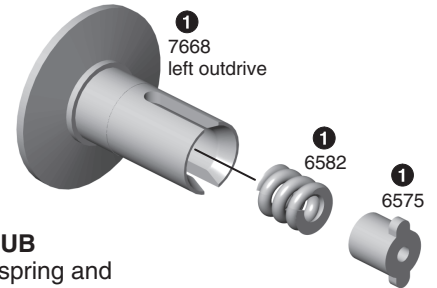

## step 3

### SET UP RIGHT HUB

- 1 Slide one #6573 washer onto the #6575 bolt.
- 2 Apply a generous amount of #6588 black grease to the washer on the side facing away from the bolt head.
- 3 Place six #6574 balls into grease against the #6575 bolt and washer. Add the other #6575 washer. The grease will hold the balls in place during assembly, sandwiched between the washers. See figure for installed view.
- 4 Slide the thrust assembly into the #7667 right outdrive hub, being careful not to lose any of the balls.
- 5 Insert the #6575 bolt cover into the #7667 outdrive.

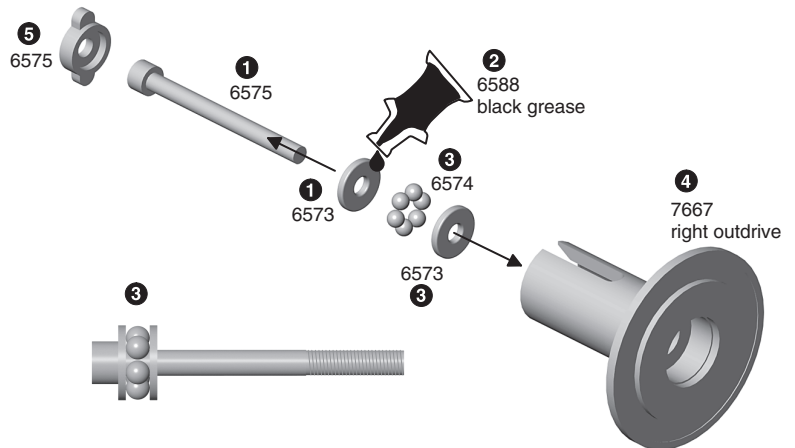

## step 4

### ASSEMBLE HUBS

- 1 Insert one #6589 bearing into the #7667 right outdrive.
- 2 Add a light coat of #6591 Tranny lube to the recessed area of the face.
- 3 Place a #7666 diff drive ring and then the gear assembly on the outdrive.
- 4 Add a light coat of #6591 Tranny lube to the #7668 left outdrive recessed area of the face.
- 5 Place a #7666 diff drive ring on the outdrive.
- 6 Push the #7668 left outdrive assembly against the other side of the gear.

### CHECK ALIGNMENT OF HUBS

- 7 Tighten the diff bolt with your 5/64 Allen wrench, but not completely.
- 8 Rotate the diff hubs several times as you are tightening the bolt to check proper alignment of the parts. **READ STEPS 9-11 CAREFULLY.**

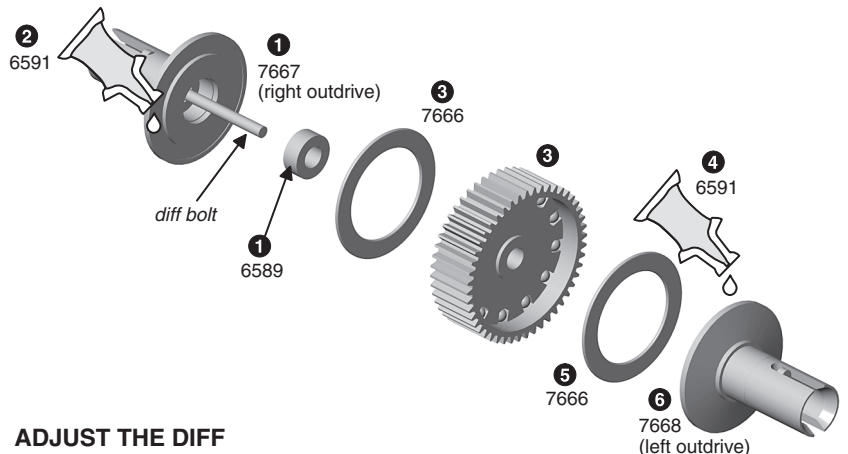

### ADJUST THE DIFF

- 9 As you tighten the diff bolt, you will notice the T-nut ears moving closer to the bottom of the diff hub slot. This compresses the spring behind the T-nut. The spring should be fully compressed at the same time the T-nut reaches the end of the slot. **CAUTION:** Pay close attention to feeling when the spring is fully compressed. **Do not overtighten the bolt.**
- 10 When you feel the spring fully compressed, loosen the diff bolt 1/8 of a turn. No more, no less. Your diff should feel smooth when turning the hubs in opposite directions.
- 11 After you have driven the truck once, recheck the diff adjustment.

# step 5

## ASSEMBLE THE TRANSMISSION

**1** Install the two #3977 bearings into the #7661 left transmission case. Install one #3976 bearing into the #7661 left transmission case.

**2** Add the #7669 spacer to the #6571 driveshaft and put both into the left case.  
**3** Install the left side of the diff assembly and #6570 idler gear into the left case.  
**4** Install the second #7669 spacer to the driveshaft.

**5** Install the remaining #3977 bearings into the right transmission case. Install one #3976 bearing into the right transmission case and put the case halves together.  
**6** Screw the transmission cases together with five #6924 screws.  
**7** Insert the #7665 roll pin into the shaft hole with your needlenose pliers. Center the pin in the shaft.

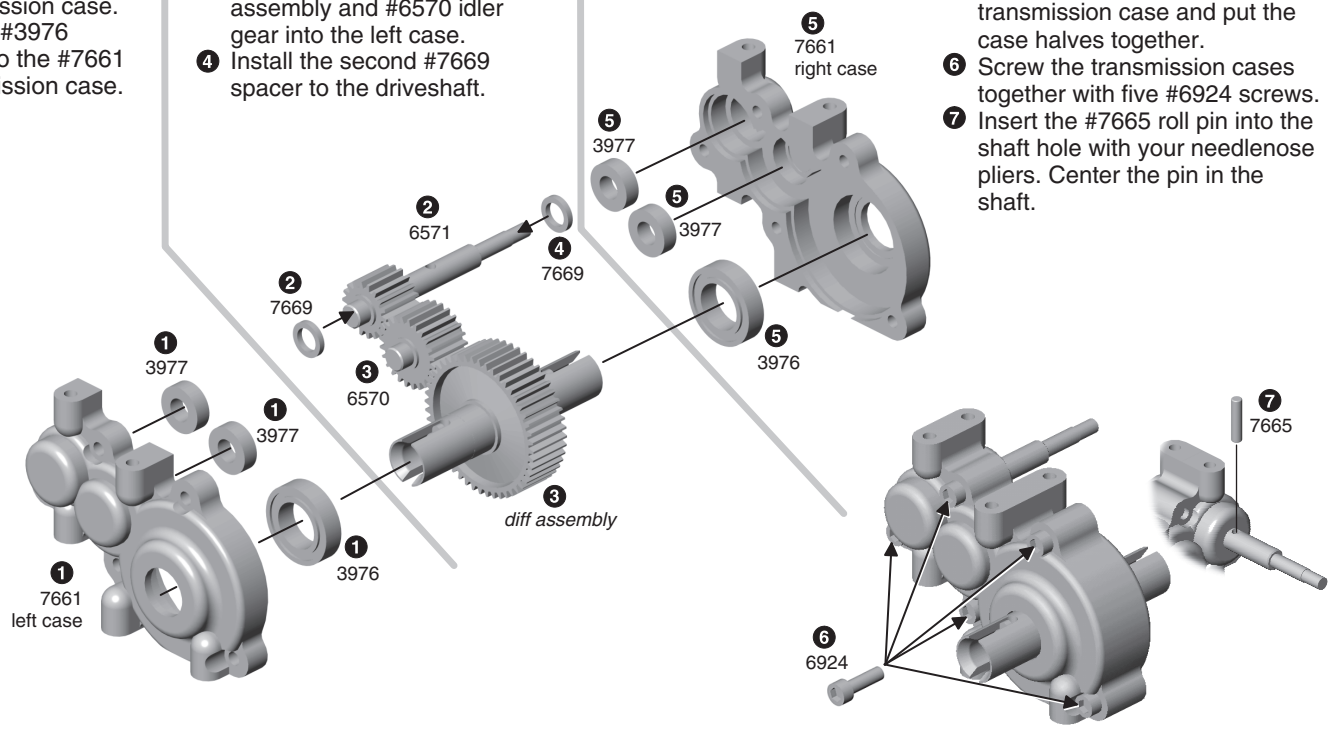

# step 6

## ASSEMBLE BRAKE ADAPTER

**1** Install your #7554 brake adapter (use existing parts from original transmission) onto the #9251 inner torque clutch hub with the notches lining up.  
**2** Install your #7553 brake disc (use existing parts from original transmission) onto the #7554 brake adapter.  
**3** Slide the brake disc assembly onto the #6571 driveshaft, lining up the pin with the notches on the hub and brake adapter.

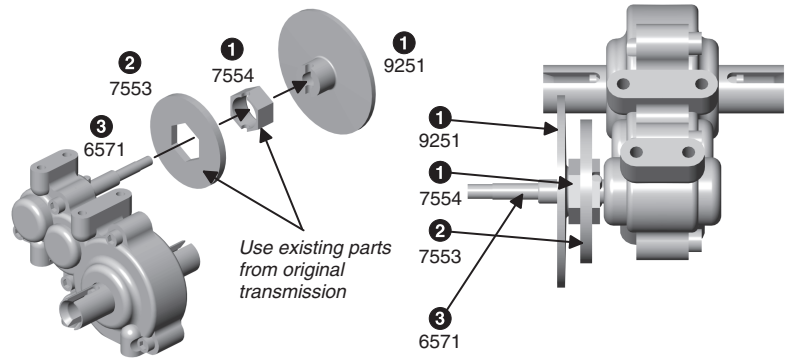

# step 7

## ASSEMBLE TORQUE CONTROL

**1** Install the #9253 clutch disc into the inner hub, then add the #9252 outer hub and #6599 bushing.  
**2** Install parts in the following order: #6594 thin silver washer, #6594 thick gold spacer, #6594 thin silver washer and #6587 black spring.  
**3** Thread on the #6629 locknut and tighten it down so the end of the shaft is flush with the end of the nut.

