

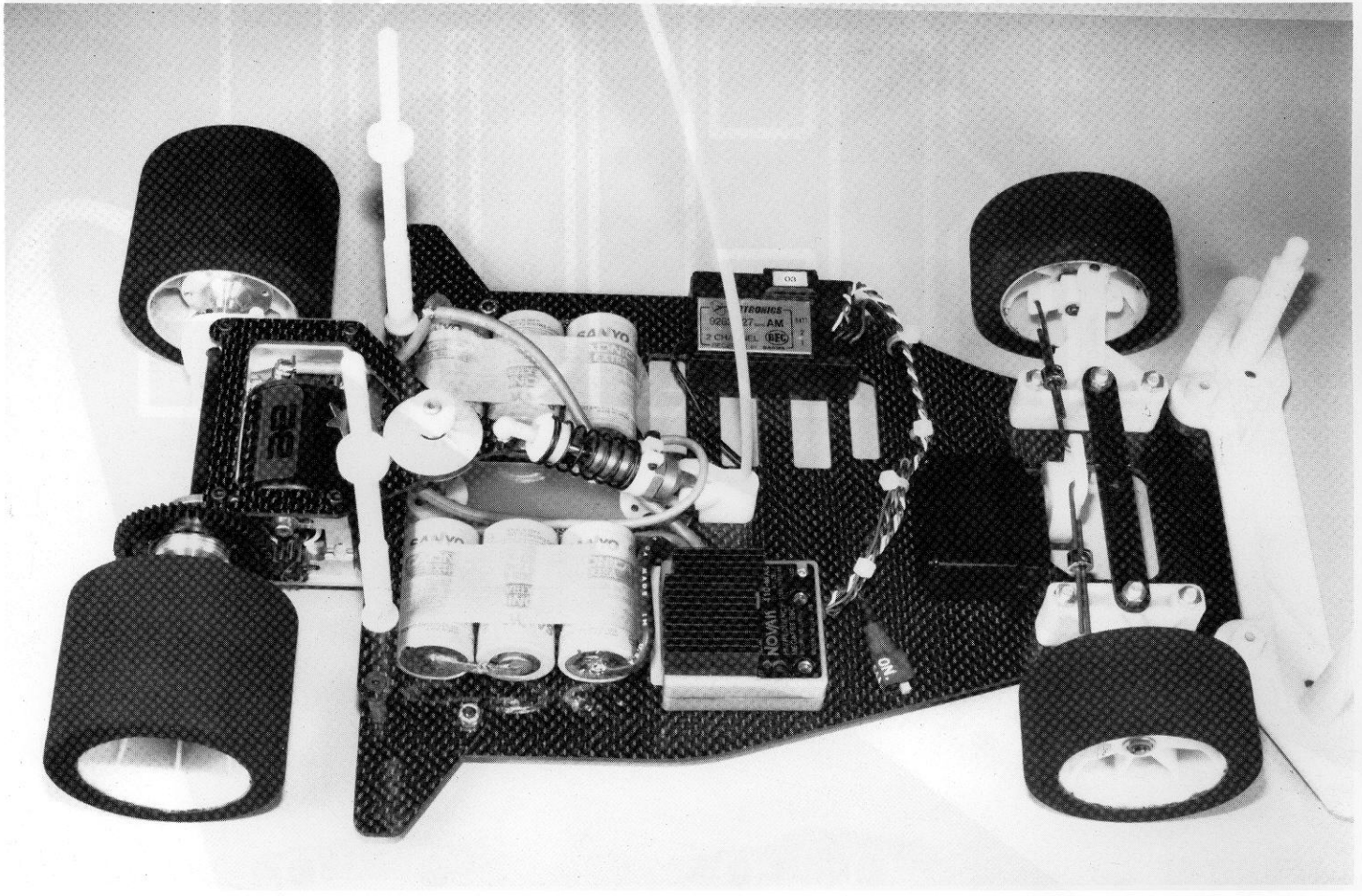
The background of the entire page is a dark grey with a repeating pattern of small, stylized racing cars in a lighter grey color. The cars are arranged in a grid-like fashion, moving from left to right.

# RC101

# **SUPER SPEEDWAY**

INSTRUCTION MANUAL

# RC10L SUPER SPEEDWAY



## CAUTION

Ni-Cd batteries are susceptible to damage when overcharged at a high rate, and can release caustic chemicals if the overcharge is severe. **Read the battery charging instructions in this manual before attempting to run your car.**

Do not stall the motor under power. If the car stops suddenly on the track, or fails to move forward when you attempt to accelerate (after hitting a wall, for instance), push the throttle control on your transmitter to the brake position immediately and attend to the car. A small rock may have stalled the gears, and if the throttle is left in the "on" position, the result can be a burned-out motor or resistor or electronic speed control unit.

If you run your car to the point where more than one cell in the pack is completely discharged, it is possible to lose radio control of the car before the drive motor stops completely. For this reason you should not operate your car in an area where it could be damaged or cause harm to others, such as near a pool of water or a busy roadway. Usually radio control will be regained as soon as you pull the car from the obstruction and the motor is allowed to free-run. If you still don't have control, then you should turn the switch off.

A partially burned-out or shorted motor can make the car appear to have radio problems. If the car slows down suddenly and the radio acts erratically even with a full battery charge, then the cause is probably the motor. Check the range of the radio. A shorted motor will draw extremely high current even under no-load conditions.

RC10L is a trademark of ASSOCIATED ELECTRICS, INC.  
©1990 ASSOCIATED ELECTRICS, INC.

# FIRST, A WORD

CONGRATULATIONS! You now have the best 1/10 scale Super Speedway Oval car in the world! The RC10L Super Speedway car is based on the design of our Nationals-winning RC10L road race car. Although the original RC10L also worked exceptionally well on flat oval tracks, we designed the RC10L Super Speedway car for the larger oval banked tracks, like Whippoorwill and the Thunderdrome Vedodrome-type tracks.

On these big banked superspeedway-type tracks we knew we were faced with a different set of race problems than on a road course or on a flat oval track. On a road course or a flat oval track the side loads on the car in the corners is extremely high, so we need a car that is closer to "square." Closer to "square" means a car whose track or width is almost the same as its wheelbase. A "square" car allows you to go around the corners much faster, giving you quicker lap times. Again, this type of car is best for the road course or flat oval tracks.

However, on the big banked ovals there is hardly any side force. The normal SIDE force in a corner is turned into a DOWN force in a BANKED corner. So, if we don't have the high side forces to contend with, then we don't need a "square" or wide car. If we don't need a wide car, why should we be pushing that big body around the track?

What we did was to call NASCAR and talk to their Tech Inspector who gave us the exact width of a Chevrolet Lumina at the bottom of the door windows. We took 1/10 of that dimension for 1/10 scale and made a new body. When racers first saw the body, they said, "It really is narrow! Is it legal?" Of course it's legal, and so is the wide RC10L, both of which fall within the ROAR rules.

The advantage that you're going to have now with your RC10L Super Speedway car is a much narrower body, so you'll be pushing less air, which will increase your speed, and because you're pushing less air (which is drag), you'll get longer run time on your batteries.



Associated Electrics, Inc.  
3585 Cadillac Ave.  
Costa Mesa, CA 92626

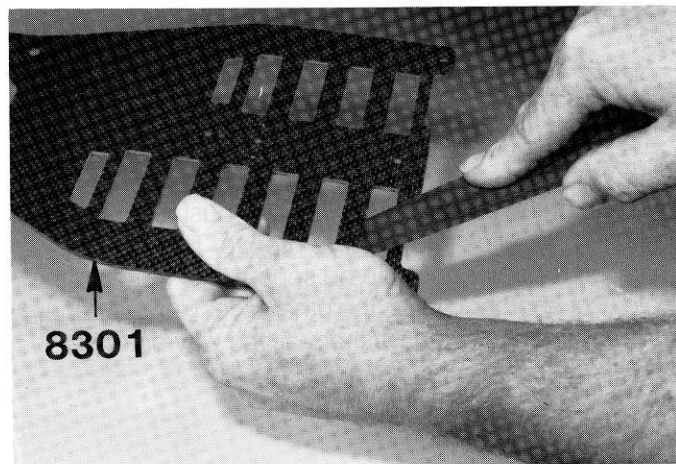
## CHASSIS PREP

**Fig. 1**— There are two RC10L kits made. The #8005, which is a fiberglass chassis kit, and the #8006, which is a graphite chassis kit. Those of you who have the fiberglass chassis can always update to the graphite chassis at a later date. The chassis are fully interchangeable.

Although these instructions show only the graphite chassis (the black one), the fiberglass car is assembled in exactly the same way these instructions show.

To begin, take your chassis, graphite or fiberglass, and notice that the BOTTOM of the chassis has the holes countersunk for screw heads. On the TOP of the chassis we want to file the battery slots at the small angle that Fig. 1 shows, so the battery cells will not be against a sharp corner that could possibly cut through the battery sleeve. Lightly file both sides, front and back, of all the slots so the battery cells have a flat surface to seat against. (Figs. 77, 78 & 79 show how the cells are seated in the chassis.) You'll also want to file the edges of the chassis where the strapping tape holding in the batteries touches the chassis. Just round these corners so they can't cut the tape.

When you're finished, wash off the chassis with running water and dry it with paper towels, and then wash your hands off with soap and water. Dispose of all the filings.

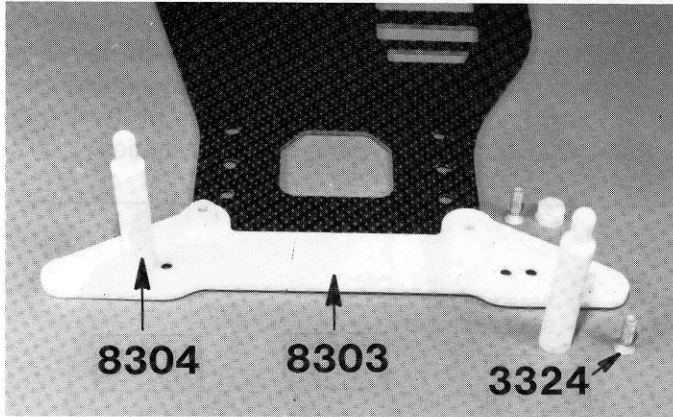


**Fig. 1**

You're now finished with Fig. 1, so put a check mark in the box next to "Fig. 1" to show this step is completed. After you've completed each step from now on, check off its box so you know which part of the assembly is completed. You won't miss any steps this way.

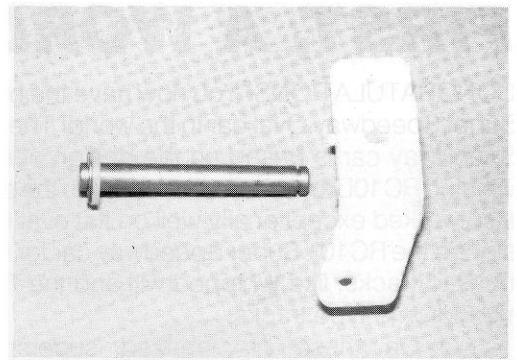
# BUMPER

**Fig. 2**— Take the chassis and the bumper from Bag #1 and mount the bumper on top of the chassis, as shown at the left half of the photo, with the two short aluminum screws and nylon nuts (displayed on the right side of the bumper). Be careful not to overtighten the screw because you can strip the threads of the nylon nut. When it feels snug, then stop tightening. If you're running the Nissan GTP body, you can install the short body mounts from Bag #2 as shown. Otherwise you must wait until the rest of the car is assembled and install the appropriate body mounts for your particular body. Mount it so the bottom of the body is even with the chassis.



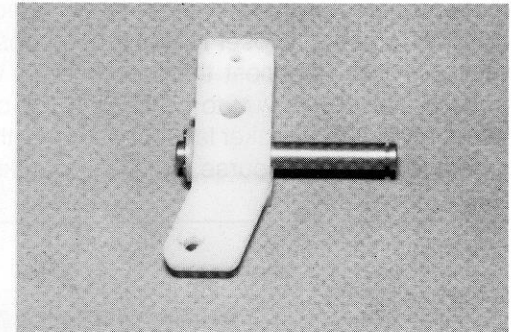
**Fig. 2**

**Fig. 4**— The axles should now look like this.



**Fig. 4**

**Fig. 5**— Now tap the axles into the #3211 front steering blocks in the direction shown. The axle will go in tight, so support the steering

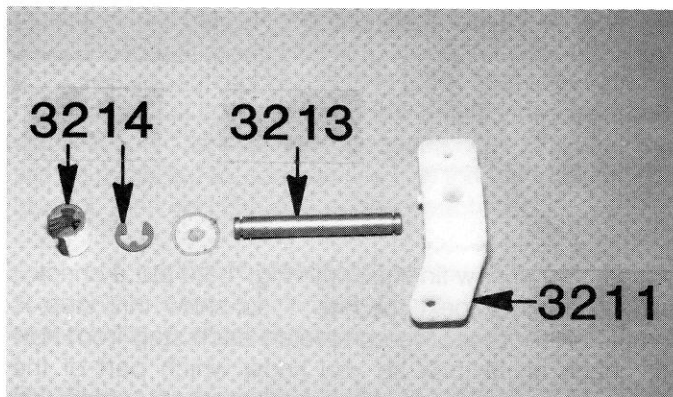


**Fig. 5**

block before driving the axle in. Support it by using a board with a small hole in it, or a vise. Set the block on top of the vise and drive the pin downward through the slightly opened jaws. Assemble both blocks. Your front blocks so far should look as shown.

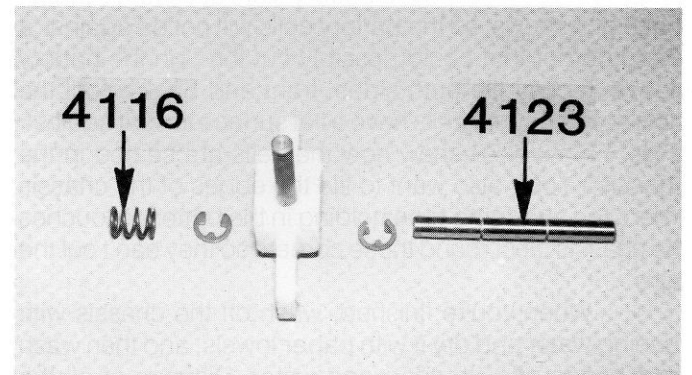
# FRONT END

**Fig. 3**— Empty Bag #2 into a paper plate. Take one of the #3213 front axles and push in one of the #3214 "E"-clips into the axle groove. The "E"-clips are taped together and can be seen a little better in the photo. Put another clip on the other axle. Now slip one of the small white nylon washers all the way onto the axles and up against the "E"-clip.

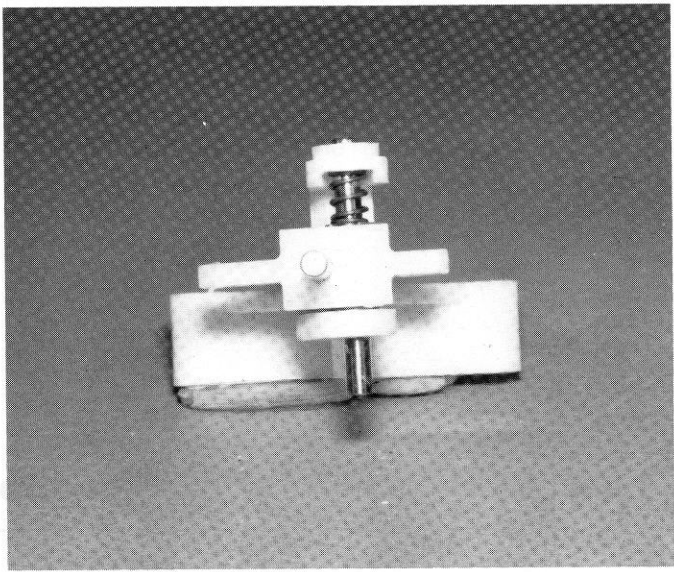


**Fig. 3**

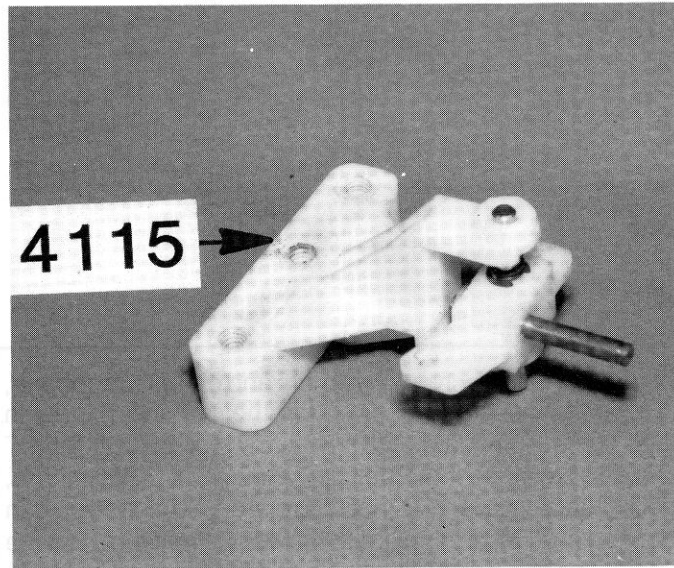
**Figs. 6, 7 & 8**— Now we're going to join the steering block to the #4115 front suspension arms. Place the steering block in the arm as shown in Fig. 7; place a spring on top of the arm where shown. Slide the #4123 kingpin into the suspension arm holes through the steering block and spring. Now put an "E"-clip into each of the two grooves in the kingpin. It's easier to put in the clip by the spring first, and then to put the clip on the bottom of the steering arm last. It will be a close fit but they will go on. Make sure they're securely in the grooves. Pushing them in with a small screwdriver seems to work best. Assemble both blocks.



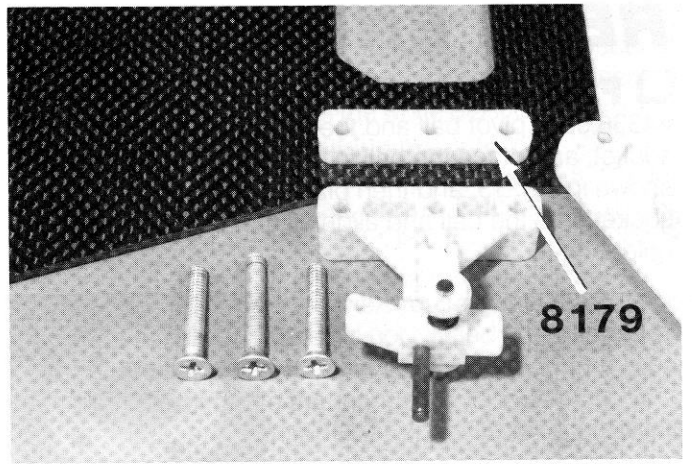
**Fig. 6**



**Fig. 7**

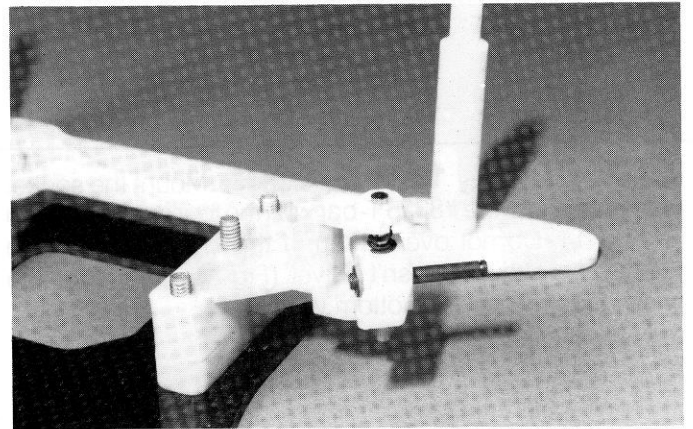


**Fig. 8**



**Fig. 9**

**Fig. 10**— The mounted right hand side should look like this. Now mount the left hand side.



**Fig. 10**

**Fig. 9**— Now we mount the suspension arms to the chassis. The 1/4" thick spacer goes on the chassis first, and then the suspension arm goes on top of the spacer. Make sure you've got the left hand side of the arm on the left hand side of the car and the right hand side arm on the right hand side, as in Figs. 9 (right hand side) and 11 (both sides).

Use three long aluminum screws to mount each arm. Screw in and tighten the front and back screws, but leave the center screw loose. The kit also includes tapered camber shims, but it's best to start without any camber on this car.

There are also some 2° block shims in your kit to increase the castor. Try different amounts of castor, up to 6° to see which is best on your track.

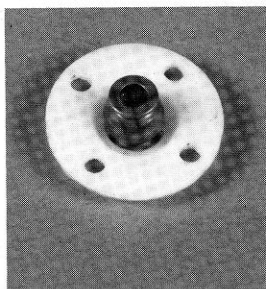
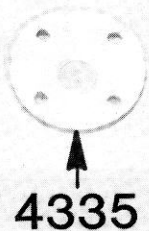
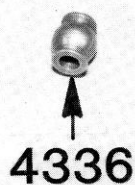
**Fig. 11**— Now mount the #8307 suspension arm brace to both suspension arms using the aluminum nuts.



**Fig. 11**

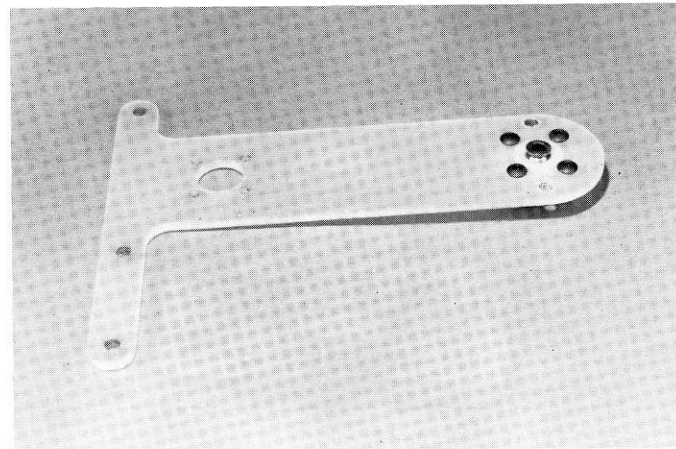
# REAR END

□ **Figs. 12 & 13**— From Bag #3 take the #4336 steel pivot ball and the #4335 plastic pivot socket, and place the ball in one side of the socket, as shown in Fig. 13, and then place the other half of the socket onto the ball and align all four screw mounting holes.



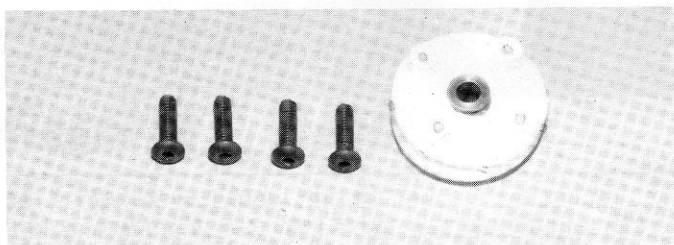
**Fig. 12**

**Fig. 13**

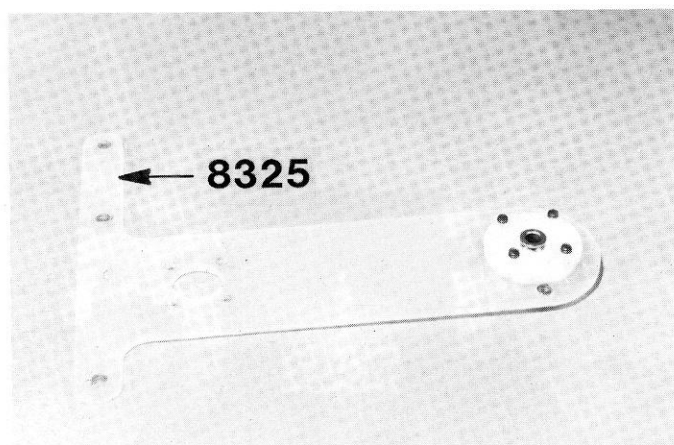


**Fig. 15b**

□ **Figs. 14, 15a & 15b**-- Mount the socket assembly onto the #8325 T-bar with the four screws shown in Fig. 14. Do not overtighten. If this ball is tight in the plastic, it's okay; it doesn't swivel. (Fig. 15a shows the top view; Fig. 15b shows bottom view.)

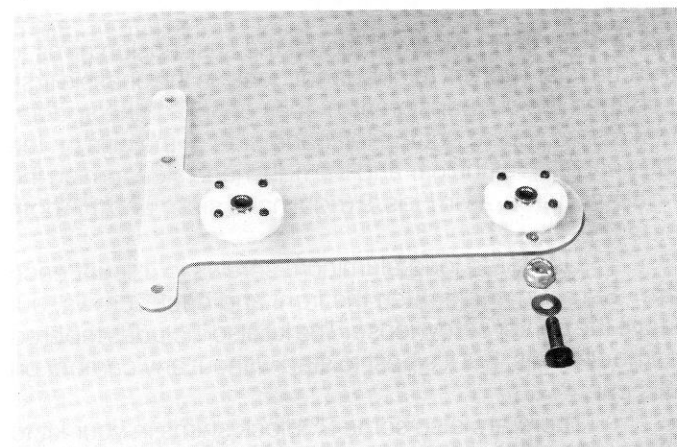


**Fig. 14**



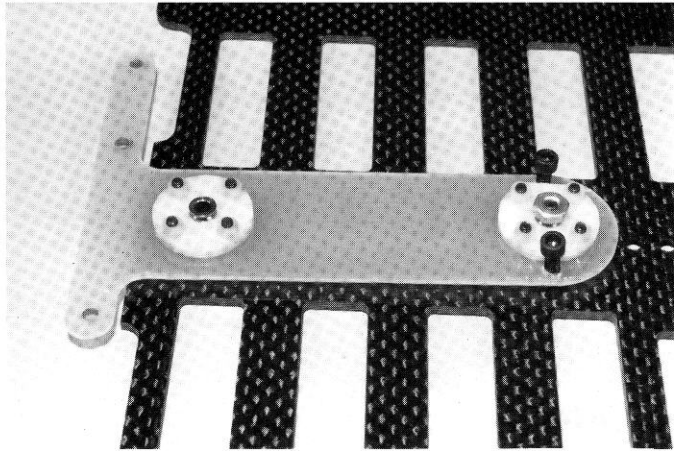
**Fig. 15a**

□ **Fig. 16**— Now assemble and mount the second, rear socket assembly like you did the first one. Except in this socket, the ball **MUST BE VERY FREE, BUT NOT LOOSE**. Now see if the ball is **PERFECTLY FREE**. If it is, good, leave it as is. If it's not, there are two things you can do. You can unscrew all four screws one half turn. But the best thing to do is to take the ball back out and polish it. You can do this by placing a 4/40 screw in the ball and securing it with a nut and turning the screw in a drill press, polishing the ball with crocus cloth or #660 wet or dry sandpaper. Re-install the ball and make sure it's **PERFECTLY FREE**, but **NOT LOOSE**.

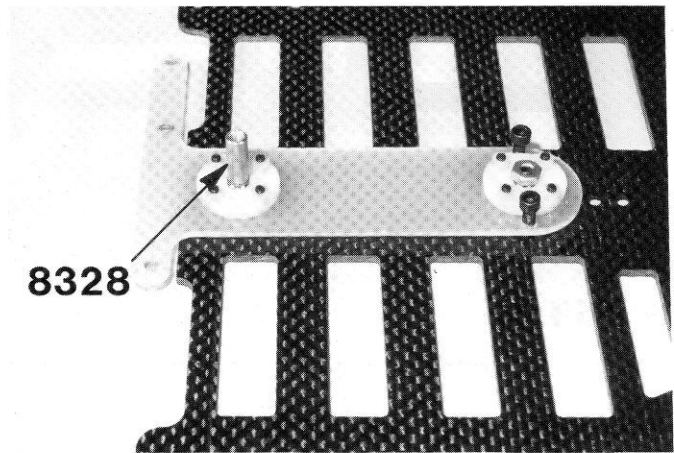


**Fig. 16**

□ **Figs. 17 & 18**—Mount the T-bar onto the chassis as shown in Fig. 17, with the short 4/40 flat head allen screw in the front and the longer screw in the rear and with the locknut on the front screw and the short threaded aluminum tube #8328 on the rear.



**Fig. 17**

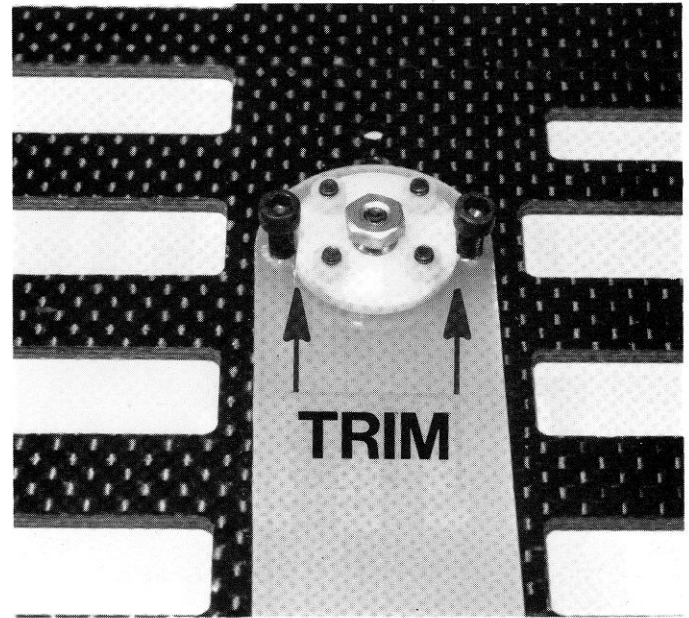


**Fig. 18**

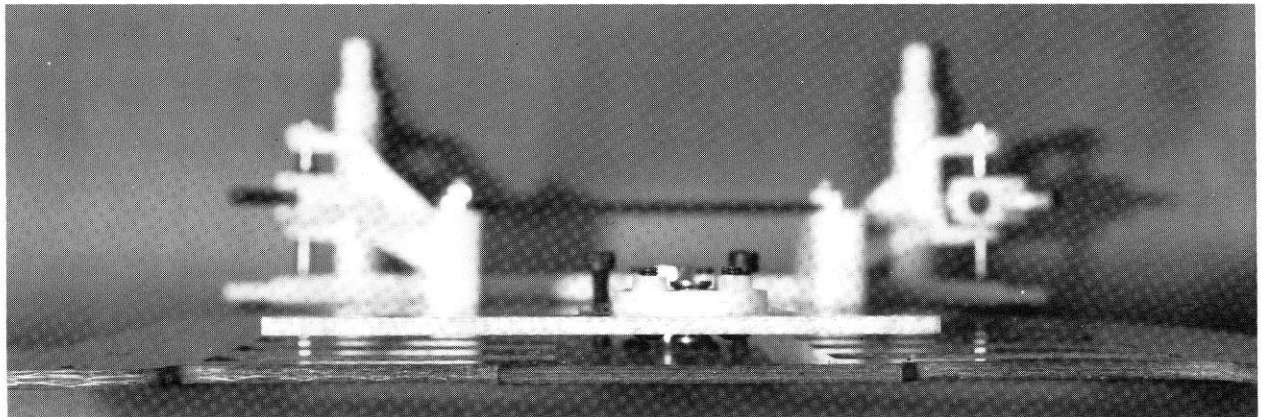
□ **Figs. 18, 19 & 20**— We'll want to install the two allen head 4/40 "tweak" screws next, but because we've narrowed the T-bar and moved the screws closer in, we'll have to trim off some of the white plastic pivot socket, as shown in Fig. 19, to clear the two screws.

Now, install the two allen head "tweak" screws in the front of the T-bar, as shown. **TIGHTEN THESE SCREWS ONLY UNTIL THEY JUST TOUCH THE CHASSIS. DO NOT OVERTIGHTEN.** They should also be screwed in evenly, so that when you're done, the T-bar is parallel to the chassis, and it's not twisted in relation to the chassis. We'll talk more about actually tweaking the car later at the back of the manual.

*Racer's Tip:* Most of the Expert Class racers like to cut a piece of brass shim stock about 5/16" square and contact cement it to the chassis, right underneath the two tweak screws, so the end of the screw hits the brass instead of the chassis. This keeps the screws from digging into the chassis itself.

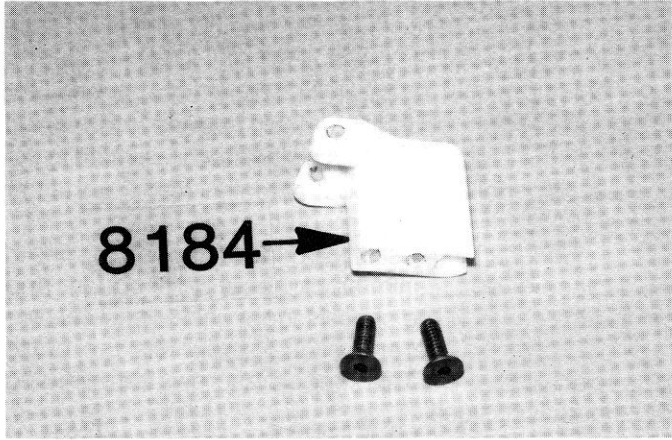


**Fig. 19**

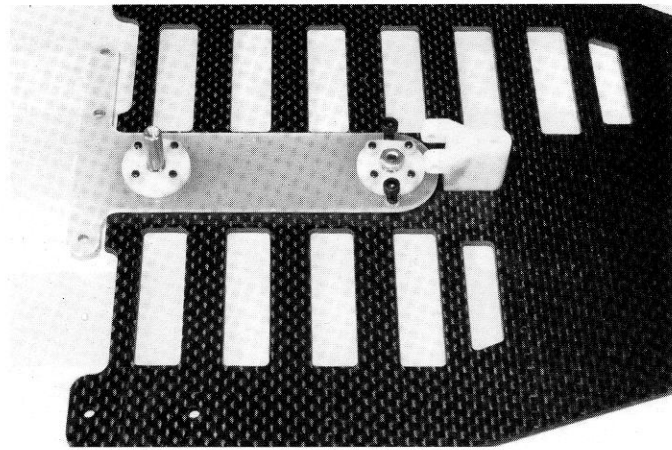


**Fig. 20**

□ **Figs. 21 & 22**— From Bag #4 remove the #8184 shock/antenna mount and carefully trim off the small round shock bushing and save it for the shock installation (Figs. 64 & 65). Install the #8184 shock/antenna mount with the two allen flat head screws.

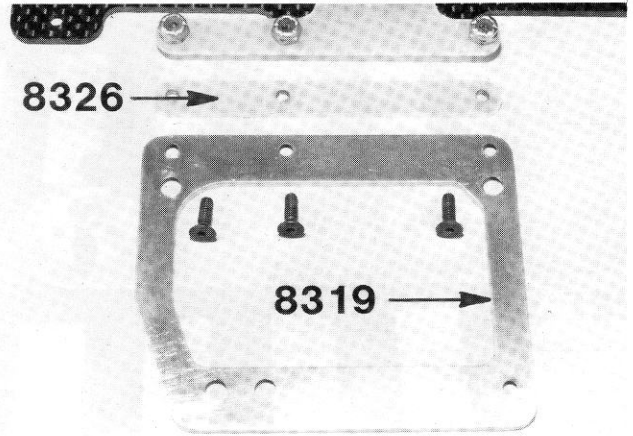


**Fig. 21**

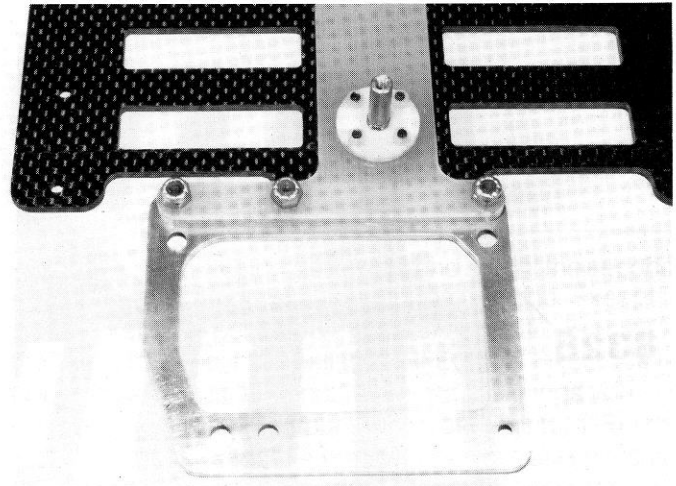


**Fig. 22**

□ **Figs. 23 & 24**— From Bag #5, we'll install the #8319 lower brace. First place the #8326 fiberglass spacer UNDERNEATH the T-bar. Then place the #8319 aluminum lower brace UNDERNEATH the spacer. Assemble with the three allen screws and locknuts.



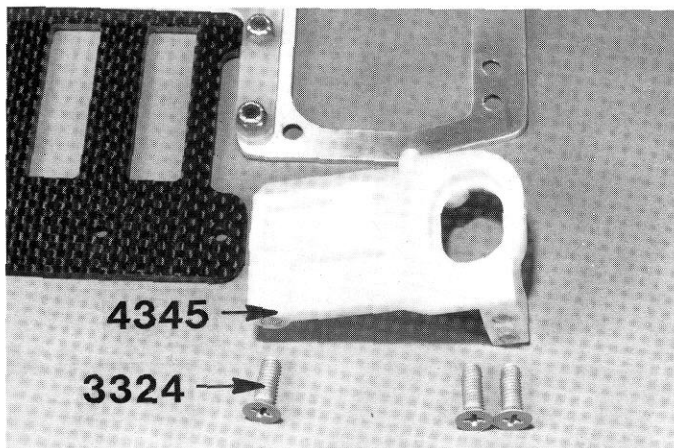
**Fig. 23**



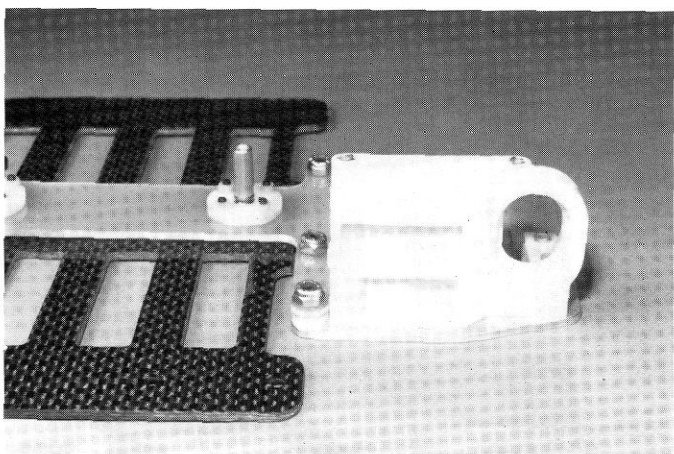
**Fig. 24**



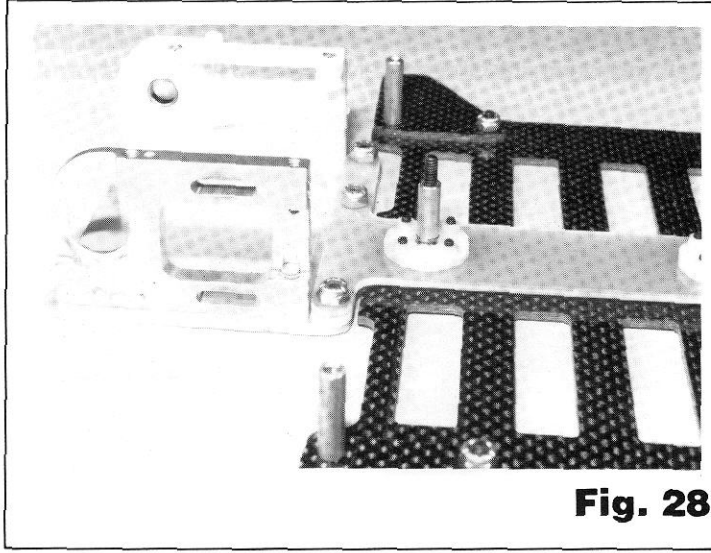
□ **Figs. 25 & 26**— Mount the #4345 left hand plastic bulkhead to the lower brace using the three #3324 aluminum screws. Do not overtighten.



**Fig. 25**

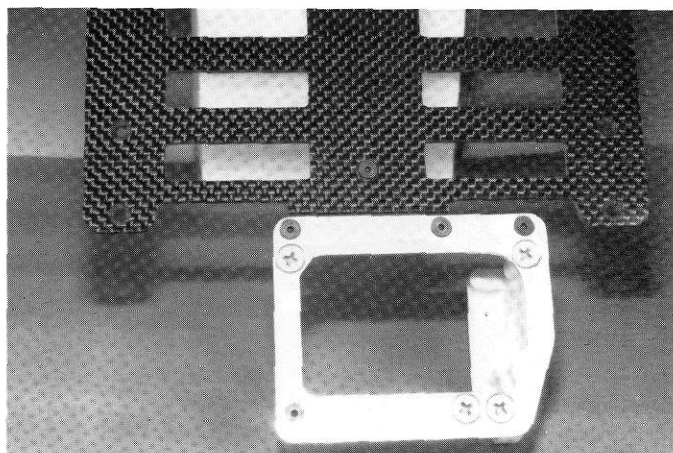


**Fig. 26**



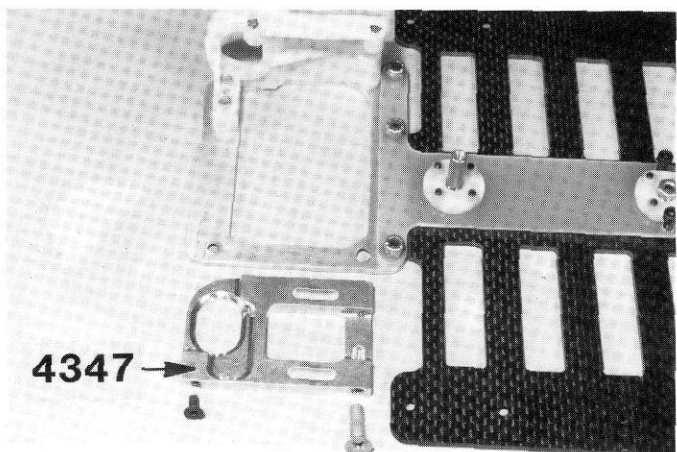
**Fig. 28**

□ **Fig. 29**— The bottom side of the car should look like this now.



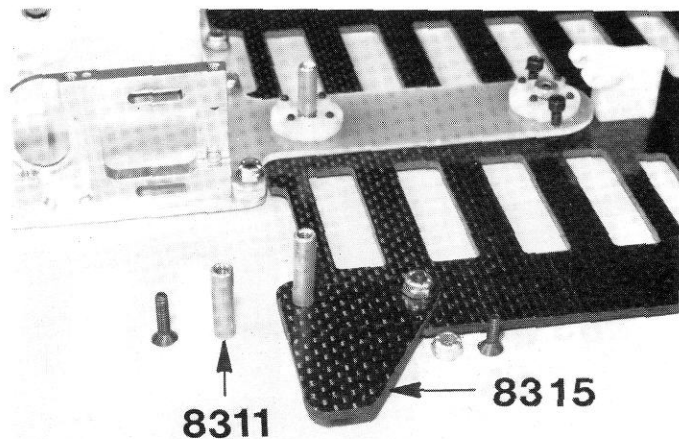
**Fig. 29**

□ **Figs. 27 & 28**— Mount the #4347 right hand aluminum bulkhead to the lower brace with one allen screw and one Phillips screw.



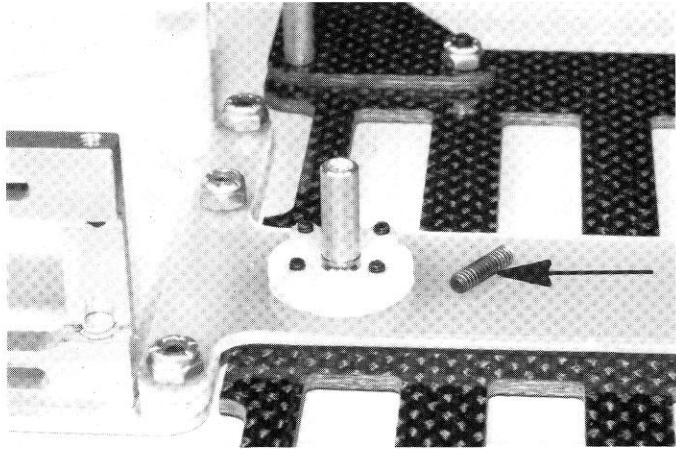
**Fig. 27**

□ **Fig. 30**— Install the #8315 left and right hand nerf bars, as shown, with 4/40 flat head screws and a locknut in front and the #8311 standoff brace in the rear.

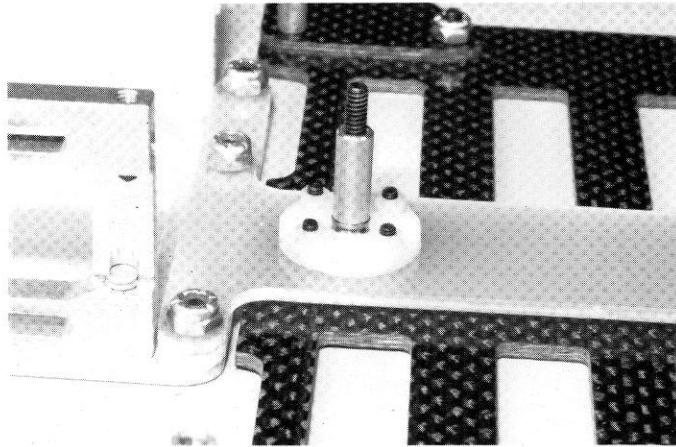


**Fig. 30**

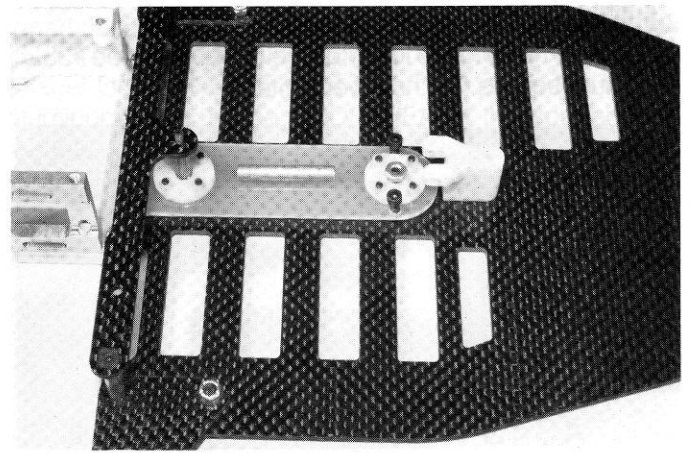
**Figs. 31 & 31a**— Screw the threaded rod half way down into the center aluminum tube, as shown.



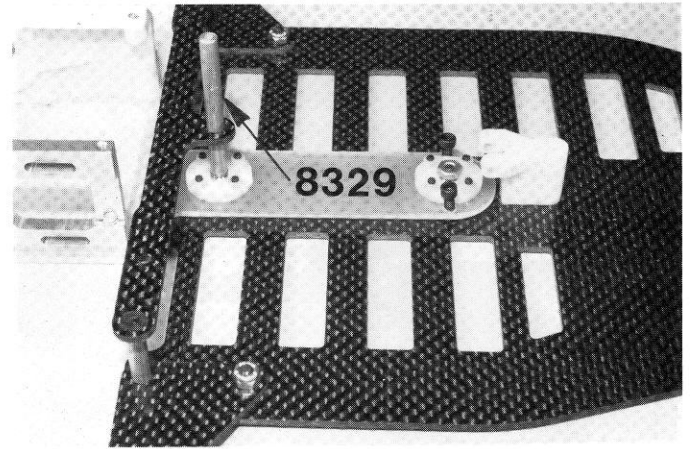
**Fig. 31**



**Fig. 31a**

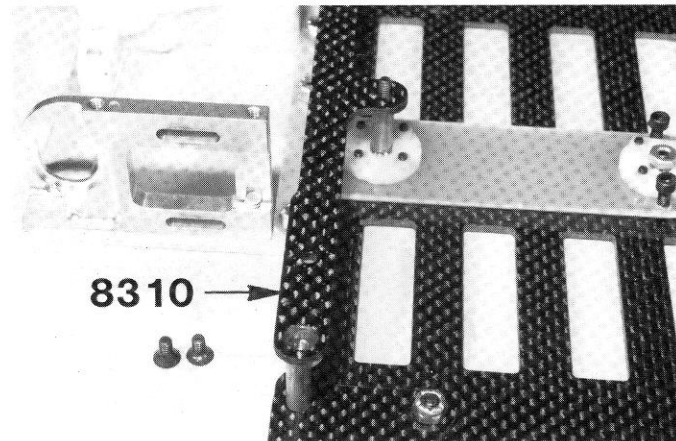


**Fig. 32a**



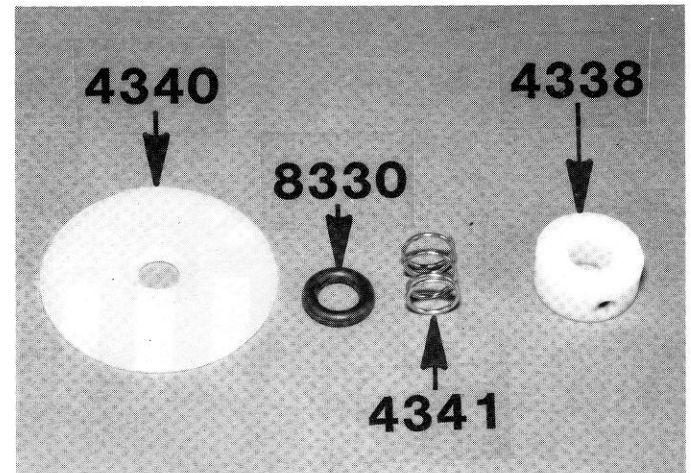
**Fig. 32b**

**Figs. 32, 32a & 32b**— Slip the #8310 rear chassis brace over the center threaded rod, and then attach it to the other two aluminum tubes with the two short flat head screws, as shown. Now, screw the longer aluminum tube onto the threaded rod, as shown, and tighten down with a pliers.



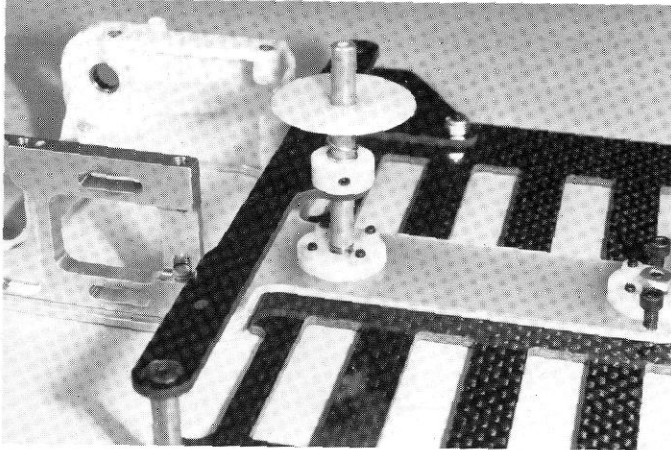
**Fig. 32**

**Fig. 33**— Slip the #8330 O-ring into the recess in the #4340 dampner washers. Install the set screws in the nylon collars.



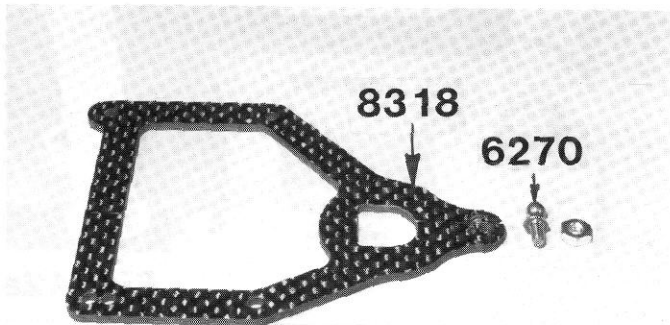
**Fig. 33**

**Fig. 34**—Slide the #4338 collar onto the tube first, then the #4341 spring and then the #4340 dampner washer on with the smooth side up. Mount it low; later we'll adjust it.

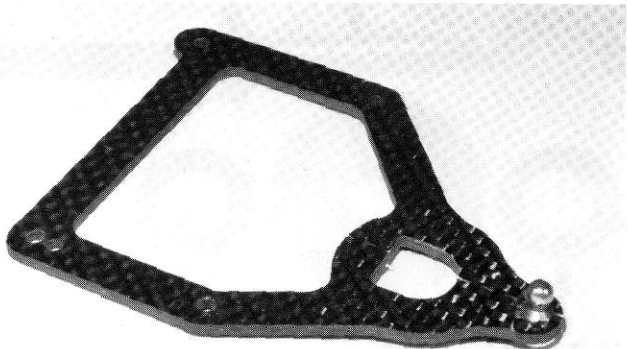


**Fig.34**

**Figs. 35 & 36**— The arrow is pointing to the upper bracket where the dampner washers ride. *Racer's Tip:* The Expert Class racers will take some #600 grit wet or dry sandpaper and sand all the edges smooth here, so that the dampner washers slide freely over the bracket. Take the #6270 steel ball from Bag #4 and mount it into the #8318 graphite upper bracket with the nut.

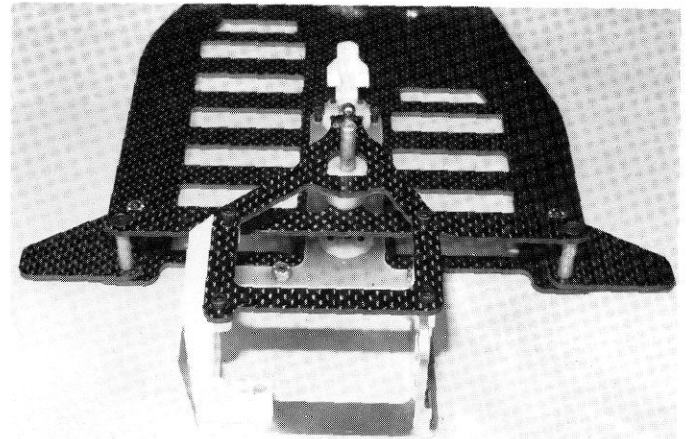


**Fig. 35**

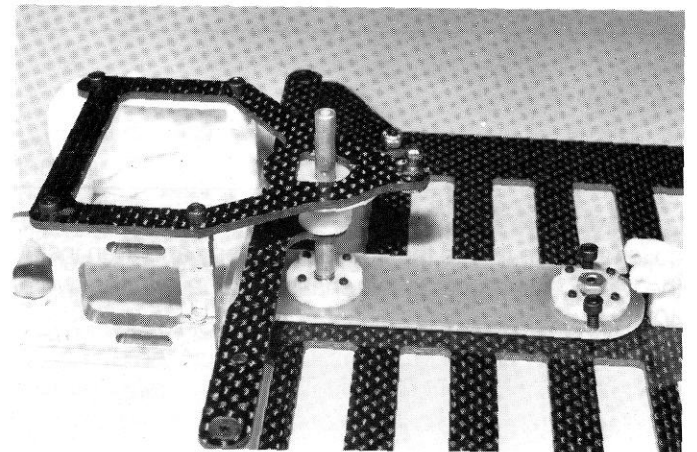


**Fig. 36**

**Fig. 37 & 38**— Mount the graphite upper bracket onto the rear end with the four allen head screws.

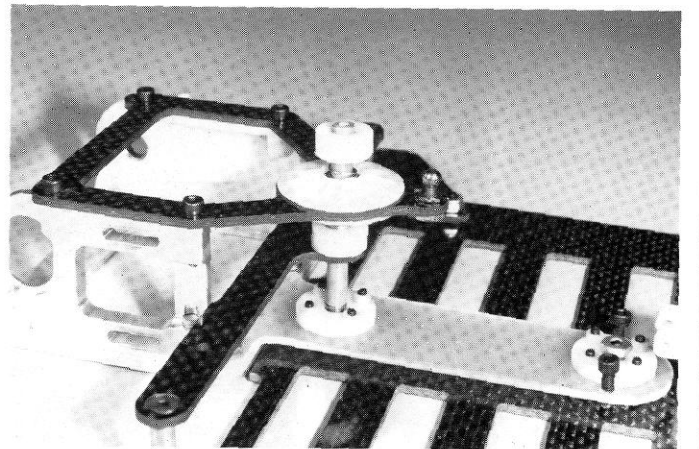


**Fig. 37**



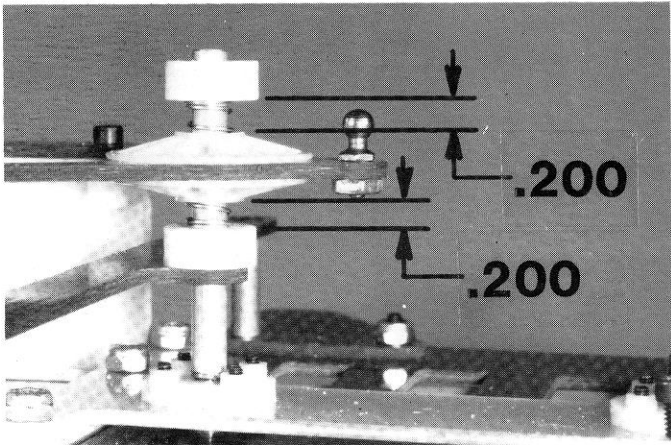
**Fig. 38**

**Fig. 39**— Install the dampner washer on the aluminum tube with the smooth side towards the bracket. Then slip on the spring and collar so it looks as shown.



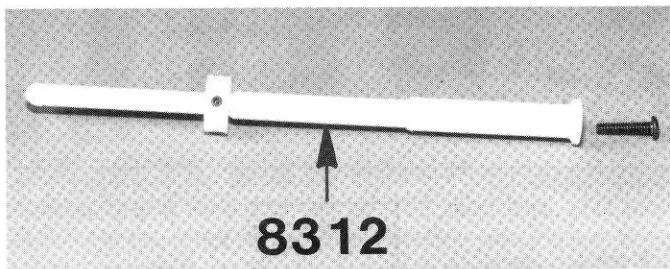
**Fig. 39**

**Fig. 40**— After the car is completely assembled, the two collars should be adjusted so both springs are collapsed exactly the same amount—about a .200" gap at each spring. We'll have to adjust this later when we come to Fig. 77. Do not check off the square yet.

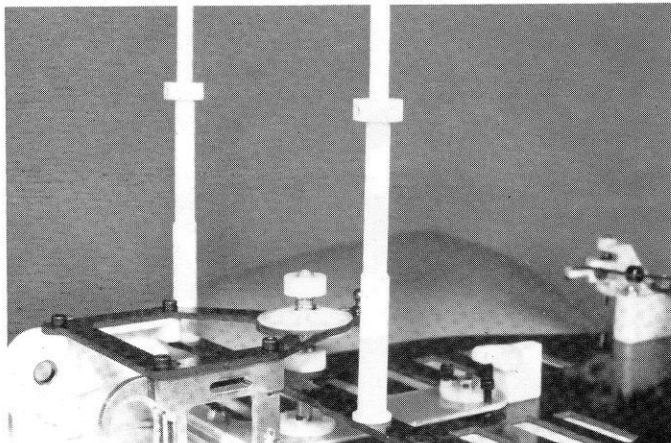


**Fig. 40**

**Figs. 41 & 41a**— Put a set screw in the nylon collar and slip it onto the #8312 rear body and then install the two body mounts to the chassis brace with the two 4/40 screws.

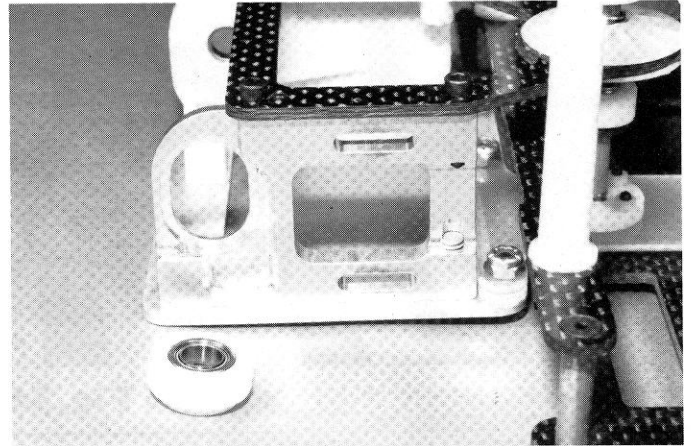


**Fig. 41**

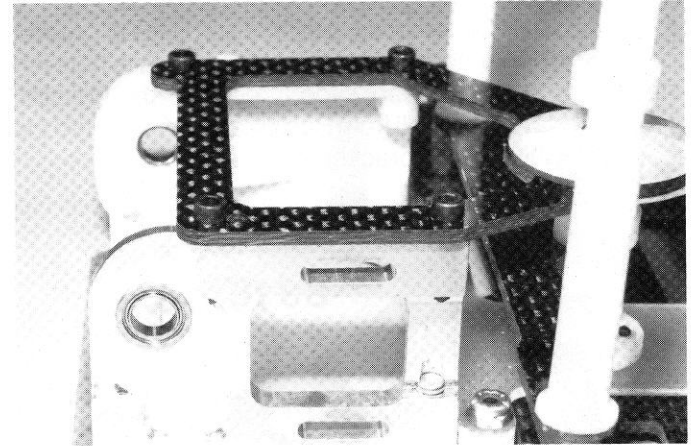


**Fig. 41a**

**Figs. 42 & 42a**— Take the #4350 plastic axle bearing height adaptors. This is the pair with the holes most offset, the ones which allow the bearings to be mounted the highest in the car. Install two #897 ball bearings in the two adaptors. Then install the two bearing adaptors in the bulkheads.



**Fig. 42**



**Fig. 42a**

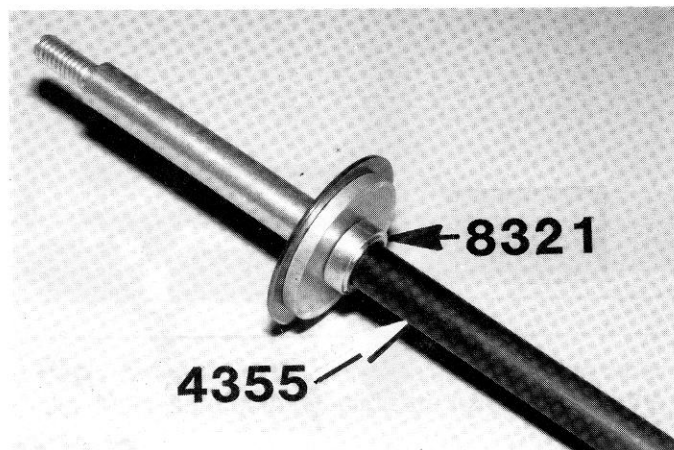
# DIFFERENTIAL

□ **Fig. 43**— From Bag #7, remove the #6653 plastic spur gear and eight of the #3432 differential balls and push them into the gear. Now place a small dab of lube on each ball from the Associated diff lube #6636. USE THIS DIFF LUBE ONLY. NEVER USE ANY OTHER. THERE IS NONE BETTER. Other types of lubes will only make the differential slip.



**Fig. 43**

□ **Fig. 44**— Slip one of the #8321 axle spacers onto the #4355 axle so that the side of the spacer that has a small step on it will be facing the ball bearing.

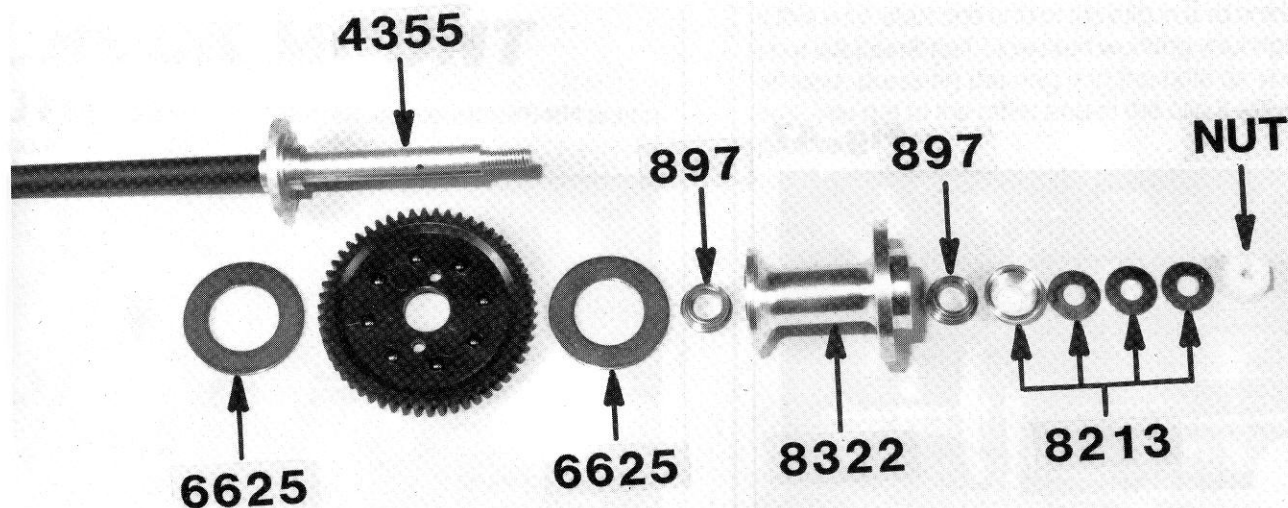


**Fig. 44**

□ **Figs. 44, 45 & 46**— We're ready to build the rear axle assembly. Slip one of the #6625 differential drive rings onto the #4355 axle, as shown in Fig. 44. *Racer's Tip:* The Expert Class racers will put a drop of Super Glue, like ZAP or Hot Stuff, where the arrow is pointing to glue the drive ring to the aluminum hub.

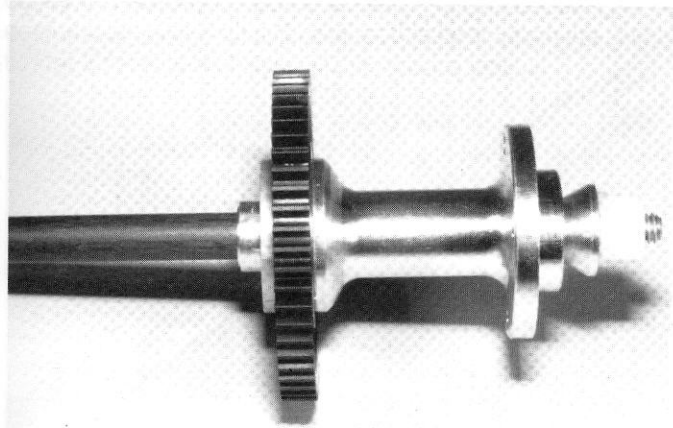
On to Fig. 45. Now slip the spur gear and the other drive ring on. Now, from Bag #8, push the two #897 ball bearings into the #8211 aluminum diff spacer and then slip the diff spacer onto the axle. You'll have to center the outer drive ring so it will align with the diff spacer.

We now use the thrust cone assembly, then the coned belleville washer with the small end toward the nut, and lastly the nut. Just tighten the nut a little bit to hold all the parts together. We'll adjust it later when we come to Fig. 49.



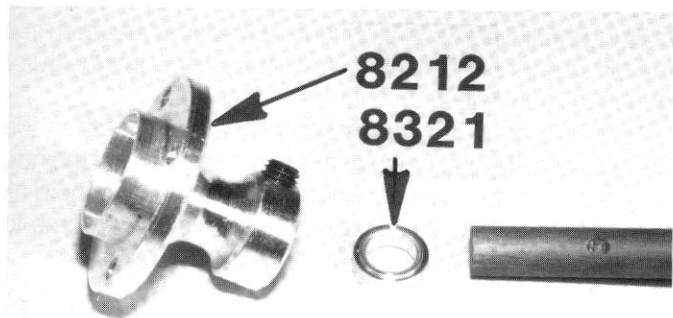
**Fig. 45**

**Fig. 46**— Your new diff should now look like this. Check the diff to make sure it's smooth.

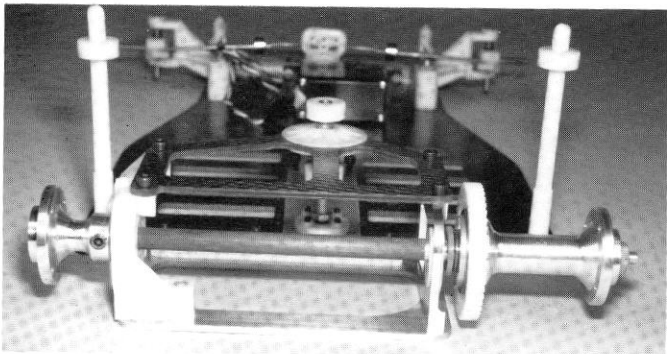


**Fig. 46**

**Figs. 47 & 48**— Slip the axle into the rear end assembly from the right hand side. Then slip one of the #8321 spacers on the axle with the small flange toward the bearing. Slide the #8212 left hand wheel hub onto the axle and lightly tighten the set screw. Now remove the wheel hub and file a small flat spot on the axle shaft where the set screw mark is. This will make it easier to remove the wheel hub later. Reinstall the wheel hub. Adjust the side end play so the axle can turn freely. You should have about a paper's thickness end play. Now tighten the set screw and check again the end play. Your installed axle should look as in Fig. 48.



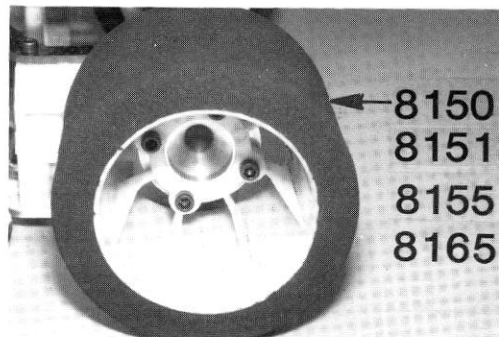
**Fig. 47**



**Fig. 48**

**Fig. 49**— Install the #8165 rear wheels/tires onto the left hand and right hand wheel hubs with the eight long allen screws. Now turn the car so the rear of the car is facing you, as in Fig. 48.

Now we adjust the diff. Hold the left hand tire in your left hand and the right hand tire in your right hand. Hold the tires still; keep them from rotating. Now with your right hand thumb on top of the gear, try to rotate the gear forward. If you haven't over-tightened the diff adjusting nut, you should be able to slip the gear and make it rotate. If the gear rotates, then tighten the adjusting nut inside the right hand rear wheel hub one flat (or 1/6 of a turn). Try to slip the gear again. If you can, turn the nut another 1/6 turn. Keep doing this procedure until you cannot move the gear with your thumb. Your diff would then be correctly adjusted.



**Fig. 49**